



# SOLAHART ATMOS HEAT PUMP WATER HEATER

325HAV

Solahart Atmos is an energy efficient Heat Pump Water Heater designed to be installed in areas where solar hot water systems may not be suitable. It is a smart renewable energy solution to replace your gas or electric water heater.

It works much like a reverse cycle air-conditioner in that the surrounding air is the heat source rather than the sun. Solahart Atmos Heat Pump provides reliable hot water for your family and is suitable for residential applications where you require energy efficient hot water, without the need for roof space.

Installation is quick and easy. Solahart Atmos can usually be installed in the same location as an outdoor electric water heater and connected up to the existing plumbing and electrical connections, making it a great energy saving replacement for an existing water heater.



**Modern Design**  
Sleek and modern low-mount design.

**No roof-mounted solar collectors**  
Ideal for installations not suitable for traditional solar water heaters.

**Eligible for STCs**  
Solahart Atmos qualifies for Small-Scale Technology Certificates (STCs), helping you reduce the up-front cost of your purchase.<sup>(1)</sup>



## HOW YOU BENEFIT



### ENERGY EFFICIENT

Energy efficient water heating. Solahart Atmos uses less energy than a conventional electric water heater.



### ELECTRIC BOOSTING

Electric booster back-up for hot water in very cold conditions.



### REDUCE ENERGY USE

Water heating energy use may be reduced by up to 60% to 64% when replacing an electric water heater.<sup>(2)</sup>



### LOW VISUAL IMPACT

No roof-mounted collectors and a tank installed discreetly on the ground.

# Technical Data

## MODEL

System Model		325HAV
Installation location - Outdoor installation only. Solahart Atmos is suitable for frost regions and it is not suitable for scaling or corrosive water areas. <sup>(3)</sup>		
Storage capacity	litres / US gal	325 / 86
Electric Boost capacity <b>3.6kW</b>	litres / US gal	180 / 47
Weight empty (cartoned)	kg / lbs	138 / 304
Weight full	kg / lbs	455 / 1003
Temperature setting	°C / °F	60 / 140
Power supply <sup>(4)</sup>	Volts / Hertz	220 ~ 240 / 50
Minimum power connection <sup>(5)</sup>	hours per day	16 or 24
Rated power input	Watts	800
Refrigerant type		R134a
Height	m / in	1.631 / 63.9
Width	m / in	0.894 / 35.2
Depth	m / in	0.638 / 25.2
Solahart Warranty <sup>(6)</sup>		5 / 3 / 2

## Water Supply

TPR valve setting	kPa / psi	1000 / 145
Expansion Control Valve (ECV) setting <sup>(7)</sup>	kPa / psi	850 / 125
Max. supply pressure with ECV	kPa / psi	680 / 100
Max. supply pressure without ECV	kPa / psi	800 / 115
Water connections	cold	Rp 3/4
	hot	R 1/2

## Climate Zones within Australia

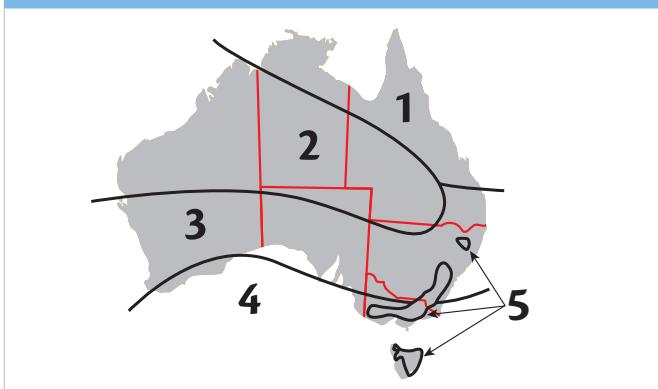

This map shows the climate Zones within Australia which will define the number of STCs<sup>(1)</sup> allocated to an approved heat pump water heater.

## Heat Pump Performance Specifications

Ambient Air Temperature	Relative Humidity	Recovery rate @ 45°C rise litres/hour	Co-efficient of Performance COP
9°C	85%	28	2.77
19°C	67%	35	3.35
33°C	60%	49	4.52

## Electric Boost Specifications

Heating unit type	Copper sheath immersion element			
Supply voltage	240 V			
<b>Recovery Rate @ 240 V Temperature Rise of:</b>				
Rating kW	Current Amps	30°C litres/hour	40°C litres/hour	50°C litres/hour
3.6	15	103	77	62

## Dimensional Drawing

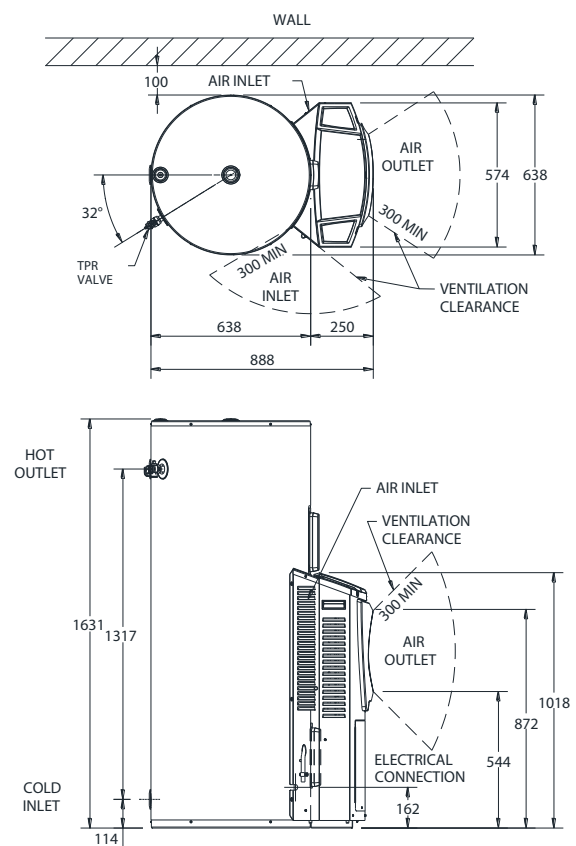

<sup>(1)</sup> Small-scale Technology Certificates (STCs) are a financial benefit to encourage the installation of solar and heat pump water heaters provided under a Federal Government legislated scheme. STCs financial benefit value is subject to change. Your installation may be eligible. Please refer to [www.solahart.com.au](http://www.solahart.com.au) for further details.

<sup>(2)</sup> Energy savings of up to 60% to 64% shown are based on Australian Government approved TRNSYS simulation modelling using a medium load and apply when replacing an electric water heater with a Solahart Heat Pump. Savings and incentives will vary depending upon your location and type of water heater being replaced. The impact on an electricity account will depend on the tariff arrangement of the water heater being replaced and where you live. Before purchase consult your energy provider for more information on cost comparisons. Refer to [solahart.com.au](http://solahart.com.au) for further information.

<sup>(3)</sup> Harsh water regions – the Solahart Warranty may not apply to the water heater if it is connected to a water supply with: a Chloride content > 250 mg/L; or a pH < 6; or is scaling with a Saturation Index > +0.4; or is corrosive with a Saturation Index < -1.0.

<sup>(4)</sup> This water heater will only operate on an electricity supply with a sine wave at 50 Hz. Devices generating a square wave or a lower frequency cannot be used to supply power to the water heater.

<sup>(5)</sup> The 325HAV Solahart Atmos Heat Pump Water Heater is recommended for connection (climate dependant) to either a 24 hour continuous power supply or an extended off-peak (min 16 hours/day) power supply. If replacing an electric water heater greater than 250 litres, heat pump connection to a 24 hour continuous power supply is recommended.

<sup>(6)</sup> Solahart Warranty Details: 5/3/2 warranty; 5-year cylinder supply, 3-year labour on cylinder, 2-year parts including labour; applies to a single family domestic dwelling only. All other applications have a 3/1/1 warranty; 3-year cylinder supply, 1-year cylinder labour, 1-year parts including labour.

<sup>(7)</sup> Expansion Control Valve (ECV) is not supplied.

Specifications and designs included in this data sheet are subject to change without notice.

Solahart Australia 1300 769 475 | [solahart.com.au](http://solahart.com.au) Solahart International +61 8 9351 4600 | [solahart.com](http://solahart.com)

Reorder code: SHDS/HP-ATMOS

IH0113\_Solahart Atmos Heat Pump Water Heater\_May 2019

**Solahart**  
HOT WATER *Free* FROM THE SUN